

單向減壓閥

Pressure Reducing And Check Valves



閥類型符號 SYMBOL

RC-※

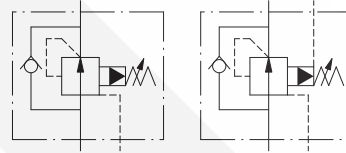

規格說明 SPECIFICATION :

型式 MODLE		最高壓力 MAX. PRESSURE kgf/cm ²	壓力調整範圍 PRESSURE ADJ. RANGE kgf/cm ²	流量 RATED FLOW l/min	重量 WEIGHT kg	
管式安裝 THREADED CONNECTIONS	板式安裝 SUB-PLATE MOUNTING					
RCT-03-※	RCG-03-※	250	1 : 7-70	50	4.9	5.5
RCT-06-※	RCG-06-※		2 : 7-140	125	8.4	8.7
RCT-10-※	RCG-10-※		3 : 7-210	250	17	15

型號說明 HOW TO ORDER :

RC G - 03 - 1 - 30 - TU - A

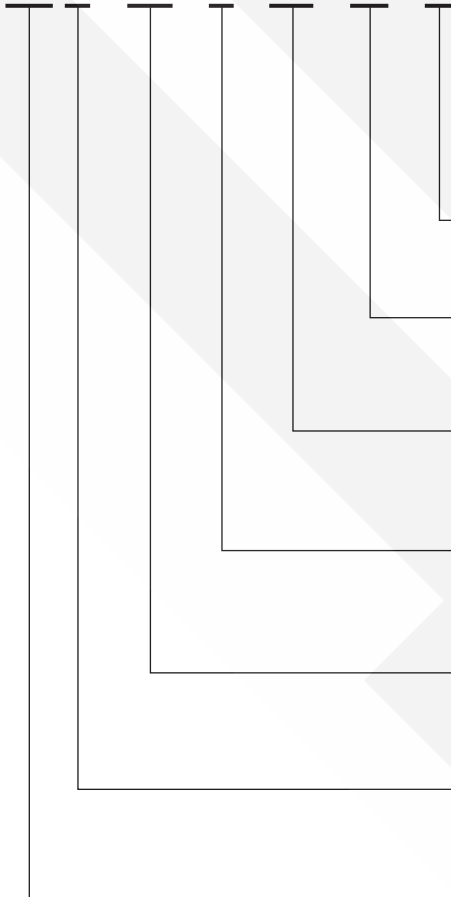

附屬品 ATTACHMENT :

型式 MODLE	安裝螺絲 SOC HOL CAP SCREW
RCG-03	M10 X 70L.....4pcs
RCG-06	M10 X 80L.....4pcs
RCG-10	M10 X 95L.....6pcs

設計編號 DESIGN NUMBER

螺牙固定閥規格RCT-03唯一型式 ONLY RCT-03 TYPE

設計編號 DESIGN NUMBER
30 : 標準型 STANDARD TYPE
32 : T型推環直結式 THRUST RING LINK TYPE

壓力調整範圍 PRESSURE ADJUSTING RANGE
1 : 7 - 70 kgf / cm² 2 : 7 - 140 kgf / cm²
3 : 7 - 210 kgf / cm²

閥規格 VALVE SIZE
03 : 3 / 8" 06 : 3 / 4" 10 : 1 - 1 / 4"

安裝型式 MOUNTING
RG : 板式安裝 SUB-PLATE MOUNTING
RT : 管式安裝 THREADED CONNECTIONS

系列編號 SERIES NUMBER

測試條件 PERFORMANCE CURVES:

測試油黏度 TEST FLUID VISCOSITY : 35 cSt

測試油溫度 TEST TEMPERATURE : 50°C

● RCT-06, RCG-06

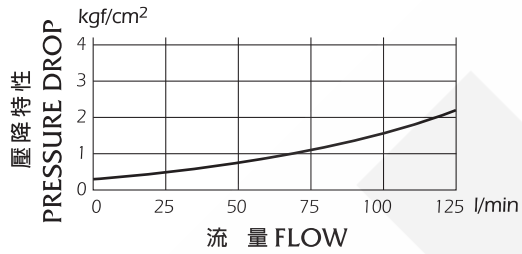

● RCT-03, RCG-03

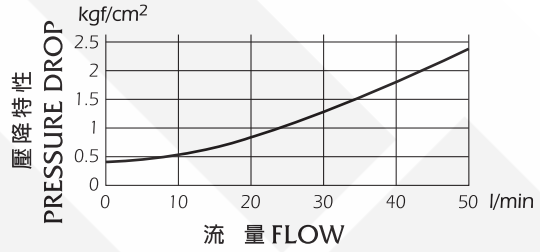

● RCT-10, RCG-10

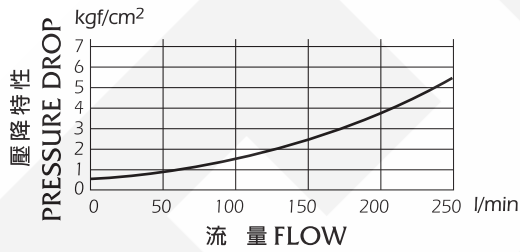

單位UNIT : mm

安裝尺寸 INSTALLATION DIMENSIONS

RCG-03-※

通用底板尺寸
APPLICATIVE
SUB-PLATE DIMENSIONS
MA - 06 - 1
(詳見 F-f1-06 Page F-f1-06)

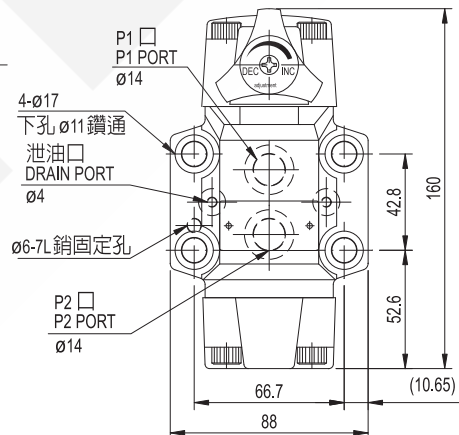
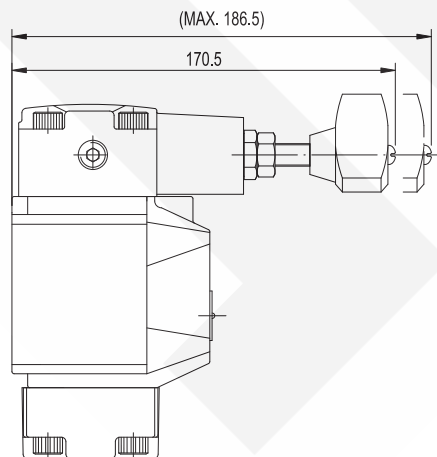
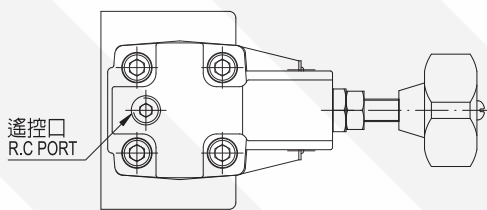

單位UNIT : mm

安裝尺寸 INSTALLATION DIMENSIONS

RCG-06-※

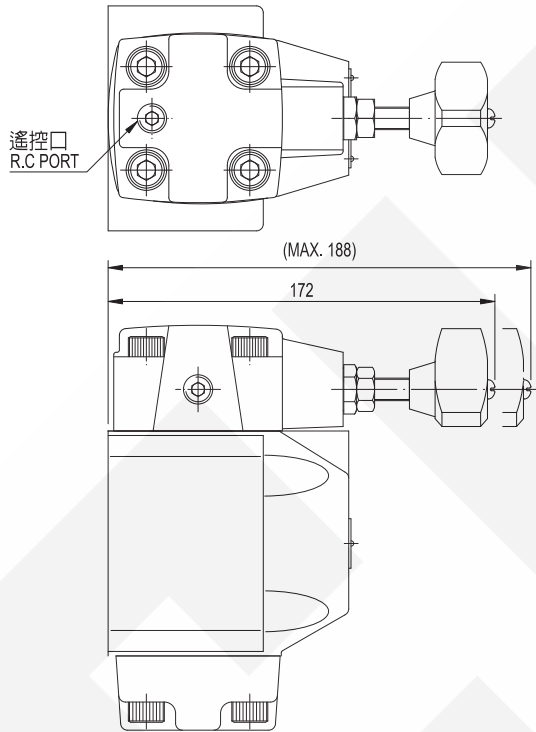

通用底板尺寸
APPLICATIVE
SUB-PLATE DIMENSIONS
MA - 06 - 2
(詳見 F-f1-06 Page F-f1-06)

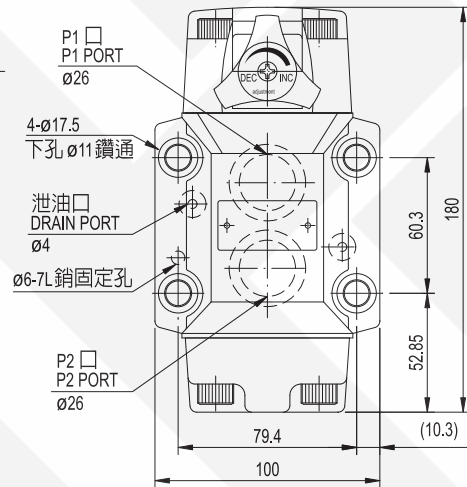

RCG-10-※

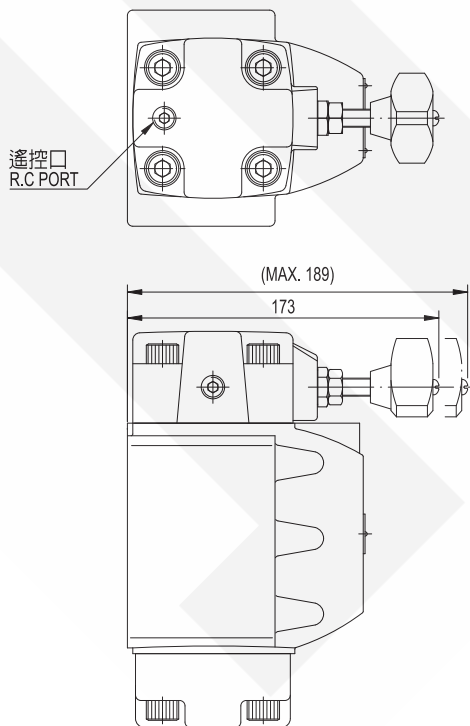

通用底板尺寸
APPLICATIVE
SUB-PLATE DIMENSIONS
MA - 06 - 3
(詳見 F-f1-06 Page F-f1-06)

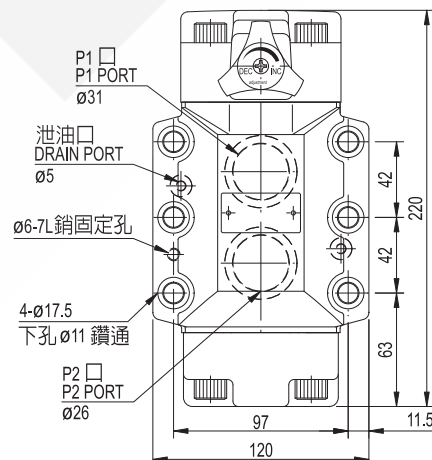

單位UNIT : mm

安裝尺寸 INSTALLATION DIMENSIONS

RCT-03-※

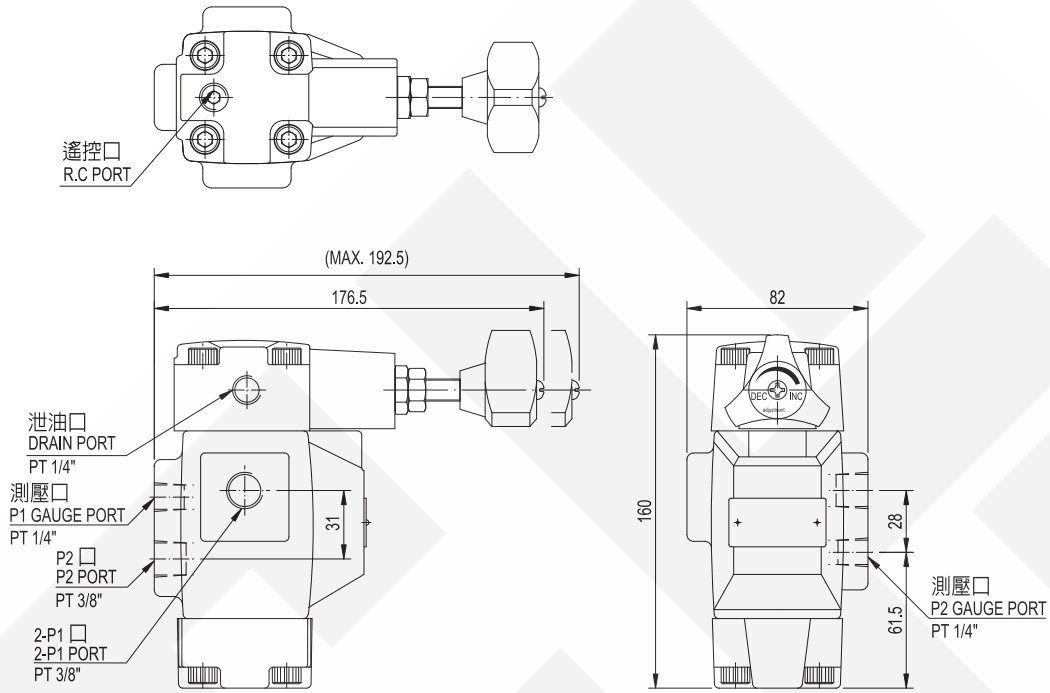

Pressure Reducing And Check Valves

RCT-06-※

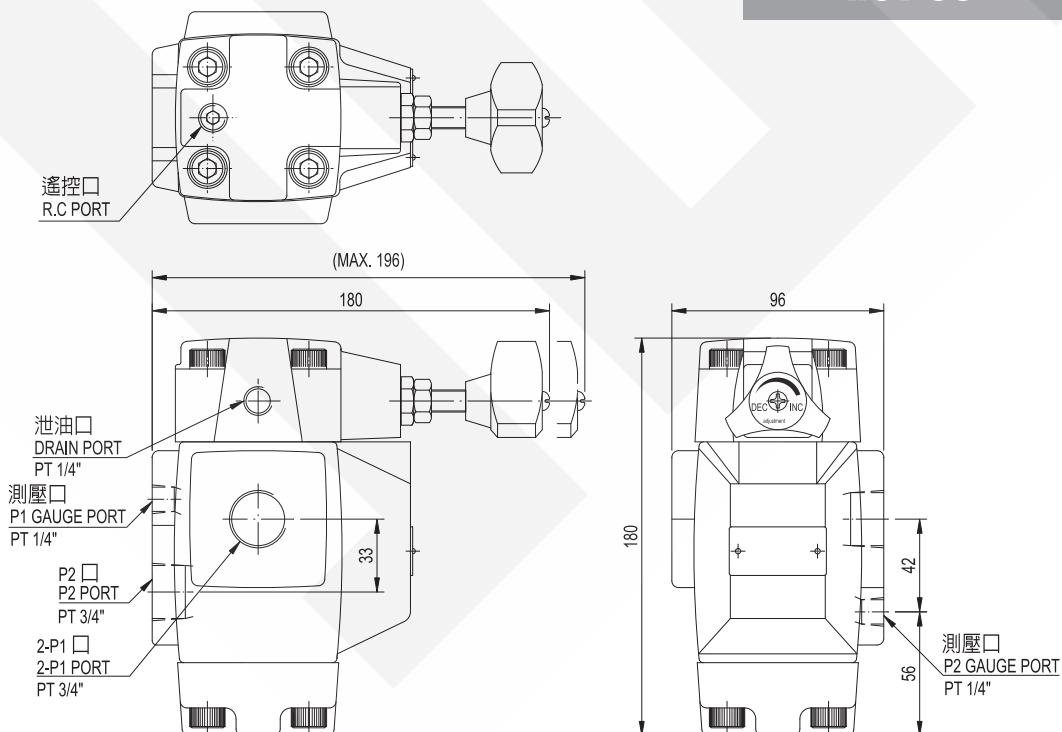

安裝尺寸 INSTALLATION DIMENSIONS

單位UNIT : mm

RCT-10-※

